

**SPECIFICATIONS OF
LCD MODULE
TECH1602B SERIES**

JULY 28, 1998

CONTENTS

Mechanical Diagram	2
Absolute Maximum Ratings	3
Description of Terminals	3
Optical Characteristics	4
Electrical Characteristics	
DC Characteristics	4
AC Characteristics	5
Write Cycle	5
Timing Characteristics	6
Block Diagram	7
Display Commands	8
Reliability and Lift Time	9
Standard Character Pattern	10

Mechanical Diagram

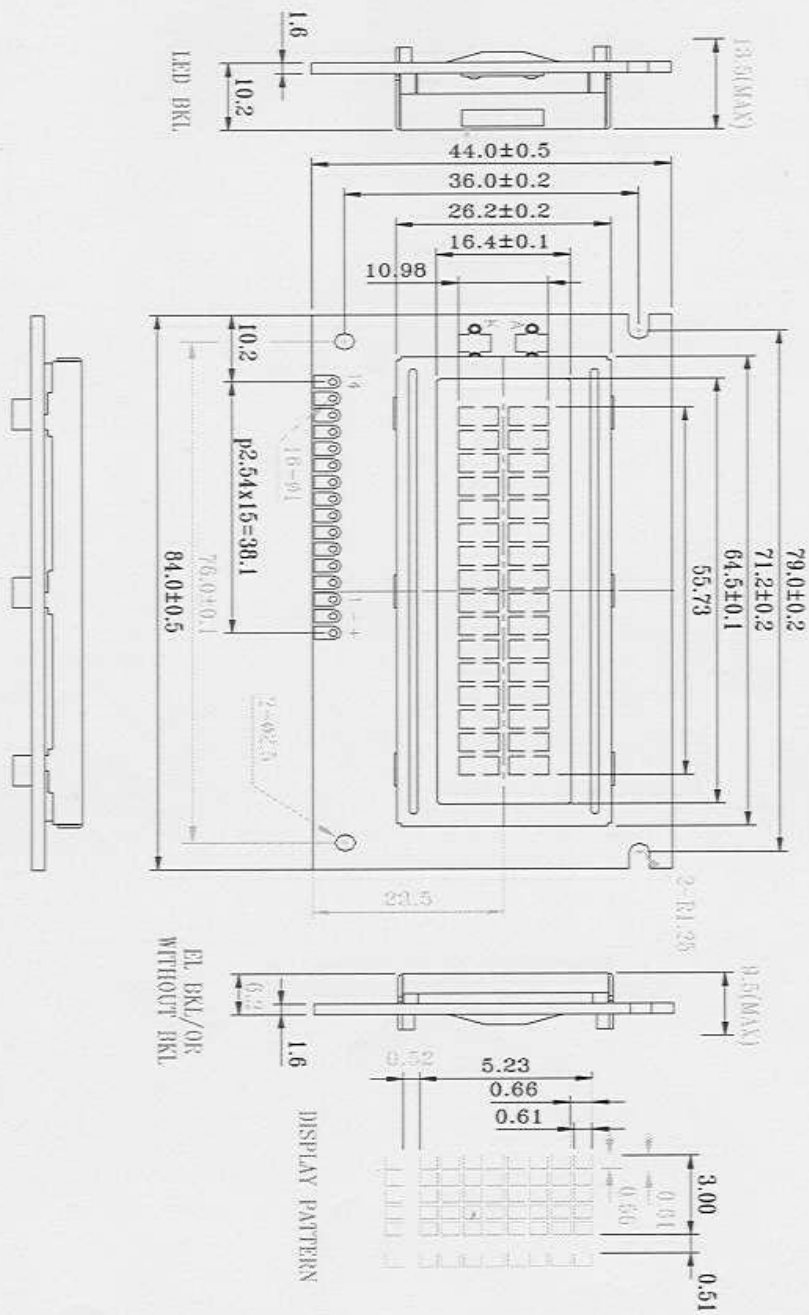

PERFORMANCE FEATURES	
IC FLUID:	TN, STN
POLARIZER:	REFLECTIVE, TRANSELECTIVE, TRANSMISSIVE
COLOR:	GRAY, YELLOW, BLUE
BACKLIGHT:	LED, YELLOW-GREEN
TEMPERATURE RANGE:	STANDARD, WIDE
CONTROLLER:	KS0066

PIN	SIGNAL/PIN	PIN	SIGNAL
1	VSS	9	DB2
2	VDD	10	DB3
3	V0	11	DB4
4	RS	12	DB5
5	R/W	13	DB6
6	E	14	DB7
7	DB0	+	LED+
8	DB1	-	LED-

Absolute Maximum Ratings

Item	Symbol	Min	Max	Unit
Power Voltage	$V_{DD}-V_{SS}$	0	7.0	V
Input Voltage	V_{in}	V_{SS}	V_{DD}	
Operating Temperature Range	T_{OP}	0	+50	°C
Storage Temperature Range	T_{ST}	-20	+60	

*Wide Temperature range is available

(operating/storage temperature as wide as $-20\sim+70/-30\sim+80^{\circ}\text{C}$).

Description Of Terminals

Pin No.	Pin Name	Input/ Output	External Connection	Function
1	VSS		Power Supply	VSS:GND
2	VDD			VDD: +5V
3	VO			V_{LCD} adjustment
4	RS	INPUT	MPU	Register select signal "0":Instruction register (when writing) Busy flag & address counter (When reading) "1":Data register (when writing & reading)
5	R/W	Input	MPU	Read/write select signal "0" for writing , "1" for reading
6	E	Input	MPU	Operation (data read/write) enable signal
7 / 10	DB0-DB3	Input	MPU	Low-order lines of data bus with 3-state, bi-directional function for use in data transaction with the MPU. These lines are not used when interfacing with a 4-bit microprocessor.
11 / 14	DB4-DB7	Input	MPU	High-order lines of data bus with 3-state, bi-directional function for use in data transactions with the MPU. DB7 may also be used to check the busy flag.
15 / 16	LED "+" LED "-"	Input	LED BACKLIGHT POWER SUPPLY	LED "+" VOLTAGE TYPE:4.2V MAX : 4.5V LED "-" : GND

Optical Characteristics

for TN Type Display Module ($T_a=25^{\circ}\text{C}$, $V_{DD}=5.0\text{V} \pm 0.25\text{V}$)

Item	Symbol	Condition	Min.	Typ.	Max.	Unit
Viewing angle	θ	$C_r \geq 4$	-25	—	—	deg
	Φ		-30	—	30	
Contrast ratio	C_r		—	2	—	—
Response time(rise)	T_r	—	—	120	150	ms
Response time(fall)	T_f	—	—	120	150	ms

for STN Type Display Module ($T_a=25^{\circ}\text{C}$, $V_{DD}=5.0\text{V} \pm 0.25\text{V}$)

Item	Symbol	Condition	Min.	Typ.	Max.	Unit
Viewing angle	θ	$C_r \geq 2$	-60	—	35	deg
	Φ		-40	—	40	
Contrast ratio	C_r		—	6	—	—
Response time(rise)	T_r	—	—	150	250	ms
Response time(fall)	T_f	—	—	150	250	ms

Electrical Characteristics

DC Characteristics

Parameter	Symbol	Conditions	Min.	Type	Max.	Unit
Supply voltage for LCD	$V_{DD} - V_O$	$T_A=25^{\circ}\text{C}$		4.6		V
Input voltage	V_{DD}		4.7		5.5	V
Supply current	I_{DD}	$V_{DD}=5.0\text{V}; T_A=25^{\circ}\text{C}$		1.5	2.5	mA
Input leakage current	I_{LKG}				1.0	μA
"H" level input voltage	V_{IH}		2.2		V_{DD}	V
"L" level input voltage	V_{IL}	Twice initial value or less	0		0.6	V
"H" level output voltage	V_{OH}	$LOH = -0.25\text{MA}$	2.4			V
"L" level output voltage	V_{OL}	$LOL = 1.6\text{MA}$			0.4	V
Backlight supply power	V_F			4.2	4.5	V

Read Cycle ($V_{DD}=5.0V+10\%$, $V_{SS}=0V$, $T_a=25^\circ C$)

Parameter	Symbol	Test pin	Min.	Type	Max.	Unit
Enable cycle time	t_c	E	500	—	—	ns
Enable pulse width	t_w	E	300	—	—	
Enable rise/fall time	t_r, t_f	E	—	—	25	
RS,R/W setup time	t_{su}	RS; R/W	100	—	—	
RS,R/W address hold time	t_h	RS; R/W	10	—	—	
Read data output delay	t_D	DB0-DB7	60	—	190	
Read data hold time	t_{DH}	DB0-DB7	20	—	—	

Write Cycle

Parameter	Symbol	Test pin	Min.	Type	Max.	Unit
Enable cycle time	t_c	E	500	—	—	ns
Enable pulse width	t_w	E	300	—	—	
Enable rise/fall time	t_r, t_f	E	—	—	25	
RS,R/W setup time	t_{su1}	RS; R/W	100	—	—	
RS,R/W address hold time	t_{h1}	RS; R/W	10	—	—	
Data setup time	t_{su2}	DB0-DB7	60	—	—	
Data hold time	t_{h2}	DB0-DB7	10	—	—	

Timing Characteristics

Write Timing

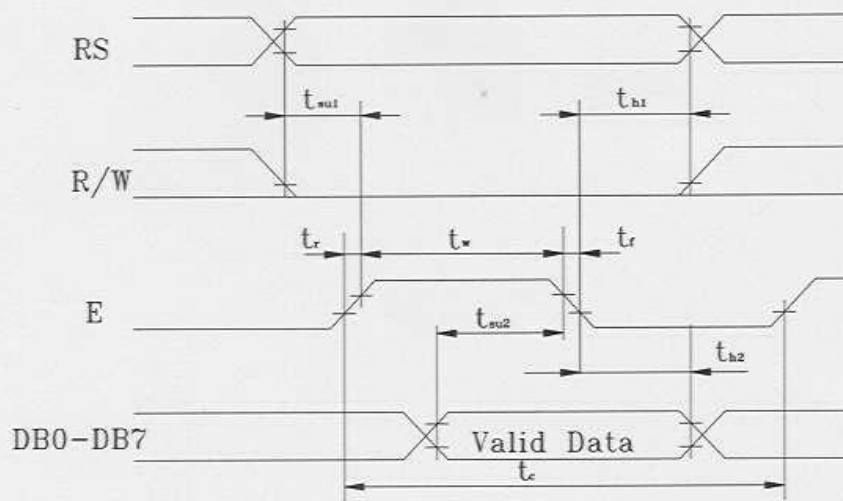

Read Timing

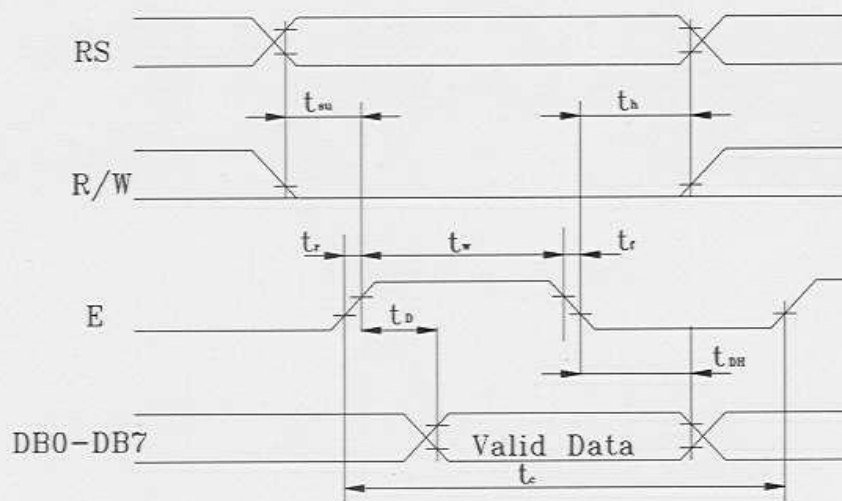

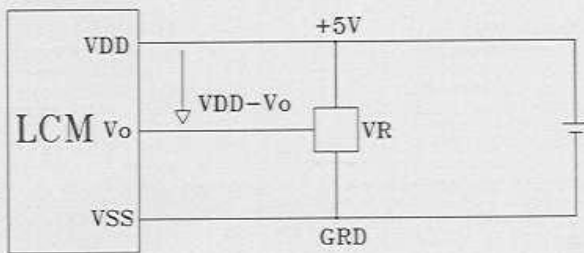
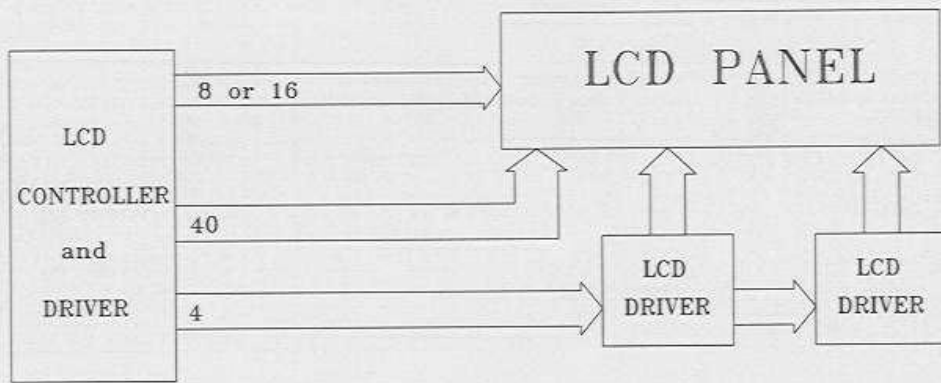

VDD- V_o : LCD DRIVING VOLTAGE

VR: 10K-20K Ω

Display command

Parameter	RS	R/W	DB7	DB6	DB5	DB4	DB3	DB2	DB1	DB0	Note	Executing time fosc=250kh z
Clear Display	0	0	0	0	0	0	0	0	0	1		1.64ms
Cursor home	0	0	0	0	0	0	0	0	1	*		1.64ms
Entry Mode Set	0	0	0	0	0	0	0	1	1/D	S	DB1=1:Increment DB1=0:Decrement DB0=1:The display is shifted DB0=0:The display is not shifted	40 μs
Display on/off	0	0	0	0	0	0	1	D	C	B	DB2=1:Display on DB2=0: Display off DB1=1:Cursor on DB1=0: Cursor off DB0=1:Brinking on DB0=0:Brinking off	40 μs
Cursor / Display Shift	0	0	0	0	0	1	S/C	R/L	*	*	DB3=1:Shifts display one character DB2=1:Right shift DB2=0:Left shift	40 μs
System Set	0	0	0	0	1	DL	N	F	*	*	DB4=1:8 bits DB4=0:4 bits DB3=1:2 lines display (1/16 duty) DB3=0:1 line display DB2=1:5 × 10 dots , 1/11 duty DB2=1:5 × 7 dots , 1/8 duty	40 μs
Set CG RAM Address	0	0	0	1	CG RAM address corresponds to cursor address						The address length that can be set is 64 address	40 μs
Set DD RAM Address	0	0	1	DD RAM address						The address length that can be set is 80 address	40 μs	
Read Busy Flag/Address Counter	0	1	BF	Address counter used for both DD&CG RAM address						DB7=1:Busy (instruction not accepted) DB7=0:Ready(for instruction)	40 μs	
Write Data	1	0	Write data									46 μs
Read Data	1	1	Read data									46 μs

DD RAM Address:

Address for line 1

Address for line 2

	1	2	3	4	5	6	7	8	9	10	11	12	13	14	15	16
00	01	02	03	04	05	06	07	08	09	0A	0B	0C	0D	0E	0F	
40	41	42	43	44	45	46	47	48	49	4A	4B	4C	4D	4E	4F	

Reliability and Life Time

1. Reliability Test

Storage Condition	Content	Evaluations and Assessment*			
		Current consumption	Oozing	Contrast	Other appearances
Operation at high temperature and humidity	40°C, 90% RH, 240hrs	Twice initial value or less	none	More than 80% of initial value	No abnormality
High temperature storage	60°C, 240hrs	Twice initial value or less	none	More than 80% of initial value	No abnormality
Low temperature storage	-20°C, 240hrs	Twice initial value or less		More than 80% of initial value	No abnormality

*Evaluations and assessment to be made two hours after returning to room temperature ($25^{\circ}\text{C} \pm 5^{\circ}\text{C}$).

*The LCDs subjected to the test must not have dew condensation.

2. Liquid crystal panel service life

50,000 hours minimum at $25 \pm 10^{\circ}\text{C}$, $45 \pm 20\% \text{RH}$.

Lower 4 Bits	Upper 4 Bits				0000	0001	0010	0011	0100	0101	0110	0111	1000	1001	1010	1011	1100	1101	1110	1111
	CG RAM (1)																			
xxxx0000	(1)			0	a	P	`	P							-	夕	三	α	ρ	
xxxx0001	(2)			!	1	A	Q	a	q						。	ア	チ	△	ä	q
xxxx0010	(3)			"	2	B	R	b	r						「	イ	ツ	×	ρ	θ
xxxx0011	(4)			#	3	C	S	c	s						」	ウ	テ	ε	ε	ω
xxxx0100	(5)			\$	4	D	T	d	t						、	エ	ト	μ	μ	Ω
xxxx0101	(6)			%	5	E	U	e	u						・	オ	ナ	1	ε	Ω
xxxx0110	(7)			&	6	F	V	f	v						ヲ	カ	ニ	ヨ	ρ	Σ
xxxx0111	(8)			'	7	G	W	g	w						フ	キ	ヌ	ウ	g	π
xxxx1000	(1)			(8	H	X	h	x						イ	ク	ネ	リ	フ	Σ
xxxx1001	(2))	9	I	Y	i	y						ウ	ケ	ル	ル	'	γ
xxxx1010	(3)			*	:	J	Z	j	z						エ	コ	ン	レ	j	≠
xxxx1011	(4)			+	;	K	[k	[オ	サ	ヒ	ロ	*	π
xxxx1100	(5)			,	<	L	¥	l	l						カ	シ	フ	ワ	φ	円
xxxx1101	(6)			-	=	M]	m]						ユ	ズ	ハ	ン	も	÷
xxxx1110	(7)			.	>	N	^	n	^						ヨ	セ	ホ	°	ñ	
xxxx1111	(8)			/	?	O	_	o	€						ッ	ソ	マ	°	ö	■

Note: The user can specify any pattern for character set.