

PC Board Layout Suggestions to Reduce EMI and RF Emissions with the Rabbit 3000 Microprocessor

Introduction

EMI Regulations

The Federal Communications Commission (FCC) regulates “unintentional radio-frequency devices” in the United States. Similarly, the European Union (EU) mandates the testing of devices for electromagnetic compatibility, and conforming devices are labeled with a CE marking. Other countries’ regulatory authorities impose similar requirements.

EMI Measuring Devices

To demonstrate compliance with these regulations, radiated and conducted emissions are measured at a standard distance, often 3 m. The field strength is measured using a calibrated antenna and a filter with a bandwidth of 120 kHz and quasi-peak detection connected to a spectrum analyzer. The radiated emissions for microprocessor-based systems that do not have a clock spectrum spreader enabled will generally be pure tones at harmonics of the clock speed, which makes it unnecessary to use a special filter or quasi-peak detection, except for final verification measurements.

The equipment needed to perform these tests may cost \$25,000 or more. Many designers will use outside laboratories to perform the tests. There is not necessarily a legal requirement to perform the tests. It depends on the type of equipment and its intended use.

Classes for EMI Testing

FCC regulations divide equipment into two classes. In addition, there are certain types of equipment such as test equipment, industrial equipment, automotive-related equipment, and medical equipment that are not subject to regulation.

	CLASS A	CLASS B
Use	Digital equipment meant for office use	Digital equipment meant for home use
FCC Limits	50 dB $\mu\text{V/m}$ at 3 m (50 dB relative to 1 microvolt per meter) or 300 $\mu\text{V/m}$	40 dB $\mu\text{V/m}$ or 100 $\mu\text{V/m}$
CE Limits* (EN55022)	30–230 MHz: 40 dB $\mu\text{V/m}$ at 10 m 230 MHz–1 GHz: 47 dB $\mu\text{V/m}$ at 10 m	30–230 MHz: 30 dB $\mu\text{V/m}$ at 10 m 230 MHz–1 GHz: 37 dB $\mu\text{V/m}$ at 10 m

* Although the test range for radiated emissions goes to 1 GHz, there will rarely be any concern above 300 MHz for Rabbit-based systems.

Unintentional Radiation

Radiation is generated by high-frequency current flows in PC boards and attached cables. Various governments regulate the levels of radiation from computing devices. The usual test is to place the device to be tested at a set distance from a calibrated antenna, and then to measure the radiation received by the antenna with a spectrum analyzer. The maximum field strength allowed is measured in microvolts per meter ($\mu\text{V}/\text{m}$) at a given frequency. The maximum field intensity allowed is specified in terms of microvolts per meter for radiation in 120 kHz wide bands. Generally the limits are in the range of 100–300 $\mu\text{V}/\text{m}$ measured at a distance of 3 m. This is expressed in dB relative to 1 μV —0 dB corresponds to 1 $\mu\text{V}/\text{m}$, and 40 dB corresponds to 100 $\mu\text{V}/\text{m}$. [dB = 20 $\log_{10}(E)$].

Sources of Radiation

Unintentional radiation is generated in two distinct ways: *differential-mode* radiation from current loops and *common-mode* radiation from antennas. An antenna is often formed by a cable attached to a PC board. If you use a ground plane and don't make certain mistakes, differential-mode radiation is not likely to be a problem at the frequencies where Rabbit microprocessors operate. Common-mode radiation most often occurs because cables are coupled to noise on the ground or power planes of the printed circuit board, and it can be quite strong. The preventive measure to avoid problems with common-mode radiation is to minimize the high-frequency electrical noise and to minimize the coupling to cables.

Differential-mode radiation increases proportional to the square of frequency. Common-mode radiation increases directly proportional to the frequency.

Differential-Mode Radiation

Differential-mode radiation can be calculated from the following formula.

$$E = 8.6 * 10^{-9} * f^2 * A * I$$

where

E is the electric field as measured in FCC tests at 3 m (in -dB $\mu\text{V}/\text{m}$)

f is the frequency (in MHz)

A is the area of the loop (in mm^2)

I is the current (in μA for a 120 kHz bandwidth)

Example

An address line toggles at 14 MHz, driving 100 pF with a 10 ns rise time. The current during the charge or discharge period of 10 ns is calculated from

$$I = C \frac{dV}{dt} = 100 * 10^{-12} * \frac{3.3}{10 * 10^{-9}} = 33 \text{ mA}$$

The average current is reduced since current only flows for 20 ns out of the 70 ns period. The average current is close to 9 mA. If the current is split between 25 harmonic frequencies whose amplitude is proportional to 1/f (a rough approximation), then the current for the 14th harmonic (196 MHz) is about 2% of the total, or 180 μ A. If the address-line trace is 100 mm long and 1 mm above the ground plane, the loop area is 100 mm². The radiation associated with this harmonic is given by

$$E = 8.6 * 10^{-9} * 196 * 196 * 100 * 180 = 5.9 \mu\text{V/M @ 3 m, or } 15.4 \text{ dB } \mu\text{V/m @ 3 m}$$

This compares to the FCC limit of 40 dB μ V. This example is modeled on address line A0 toggling at 1/2 a clock frequency of 29.5 MHz. Not many traces on a Rabbit 3000 PC board would have this much radiation, and they would not generally add linearly due to different antenna orientations and differing frequencies. The fastest toggling lines are A0 and the 8 data lines. The above example is exaggerated because these lines are not generally 100 mm long, they usually have less than 100 pF loading, and they don't toggle in a uniform manner since bus cycles have different lengths and the data lines toggle in a more or less random fashion. Taking all these factors into account, it is likely that the entire differential-mode radiation will be less than 20 dB μ V without enabling the spectrum spreader. If the spectrum spreader is enabled, these values would be reduced by approximately another 15 dB μ V/m @ 3 m to perhaps 5 dB μ V/m @ 3 m for the entire board.

On the other hand, if there is a long slot in the ground plane and the return current is diverted by 50 mm, the loop area might be increased from 100 mm² to 2500 mm², and radiation from a single line might increase by a factor of 25 or 28 dB. (Return current normally flows under a trace in the ground plane.)

Common-Mode Radiation

Common-mode radiation is the radiation emitted by an antenna, such as a wire attached to a voltage source.

The formula for common-mode radiation is:

$$E = 0.4 * f * L * I$$

where

E is the electric field at 3 m (in μ V/m @ 3 m)

f is the frequency (in MHz)

L is the length of the antenna (in m)

I is the current in the antenna (in μ A)

Example

An antenna is 1 m long. The current is 1 μ A, and the frequency is 100 MHz.

$$E = 0.4 * 100 * 1 * 1 = 40 \mu\text{V/m @ 3 m}$$

This is quite significant since the FCC Class B limit is 100 μ V/m @ 3 m.

PCB Layout Considerations

Even though the Rabbit 3000 has powerful anti-EMI features, it is still important that printed-circuit board (PCB) layout be done taking into account proper precautions against EMI. The higher the clock frequency, the worse the EMI. Expect the EMI amplitude to increase by 6 dB for each doubling of clock frequency.

The most important PC board layout goal for Rabbit 3000 systems is to minimize power-ground noise. As a practical matter, power-ground noise is the main driver of radiated emissions. Usually the main source of this noise is the Rabbit 3000 microprocessor. Minimizing power-ground noise is accomplished by blocking the escape of noise from the processor and into the power and ground planes, and by designing a power-ground system that has low impedance over a broad range of frequencies. Noise may be blocked from exiting the processor package by using suitable decoupling capacitors connected directly to the package power pins. The goal of a low-impedance power-ground system is realized by minimizing the spacing between the power and ground planes and by using low-impedance decoupling capacitors connected with low-inductance connections to the power planes.

Rabbit 3000 Die

The Rabbit 3000 microprocessor silicon die has two separately powered parts shown in Figure 1: the *core*, which is the logic in the center part of the die, and the *I/O ring*, which is located on the edges of the die and consists of the buffers that interface with the package I/O pins. The core logic is very fast with rise times of the order of 100 ps. The I/O ring buffers drive large currents whose rise times are much slower, around a few nanoseconds. Separate power pins supply power to the core and to the I/O ring of the Rabbit 3000.

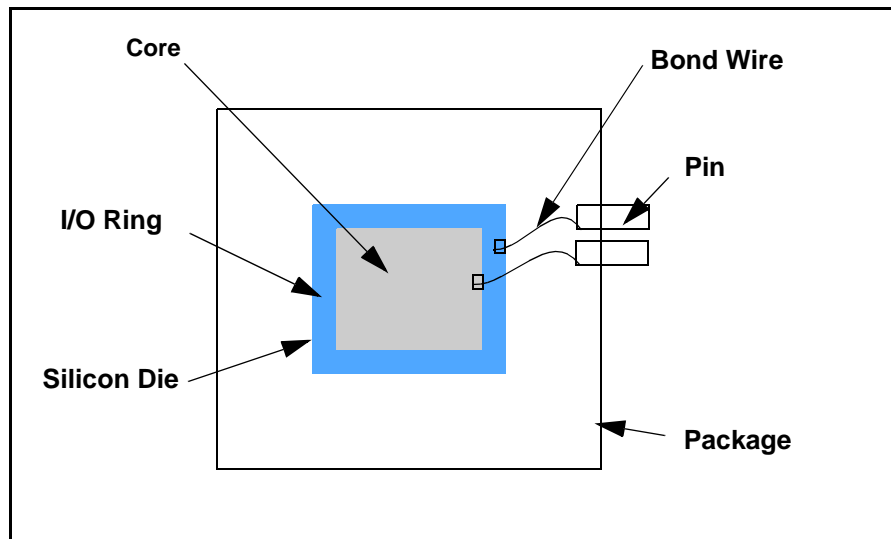

Figure 1. Rabbit 3000 Die and Package

Most of the high-frequency noise originates in the Rabbit 3000 microprocessor core. This noise then escapes the microprocessor package via the four power pins (8, 24, 72, and 88 in an LQFP package) power and the four ground pins (9, 25, 73, and 89 in an LQFP package) that provide power to the core. There are seven power pins and eight ground pins for the I/O ring. An additional power pin, pin 51, is for the battery backup of the clock, and this can be treated in the same manner as the other power pins for the purpose of decoupling.

EMI mitigation is done by adding decoupling capacitors in three areas:

1. Between the power and ground pins of the Rabbit 3000 microprocessor itself.
2. Between the power and ground pins of other memory chips on the PCB.
3. Between the power and ground planes of the PCB.

Decoupling Capacitors Around Rabbit 3000 Microprocessor

To prevent high-frequency noise produced within the Rabbit 3000 microprocessor from escaping through the power and ground system of the PCB, each pair of core power and ground pins should be decoupled from the PCB by a pair of capacitors as shown in Figure 2 below. Since the capacitors and the connecting traces form a “filter,” it is important that the vias to the ground and power planes are placed after the “filter.” Besides the core power pins, the I/O ring’s power and ground pins should also be decoupled as shown to prevent noise generated in the I/O ring from escaping and to provide a low-impedance source of switching current.

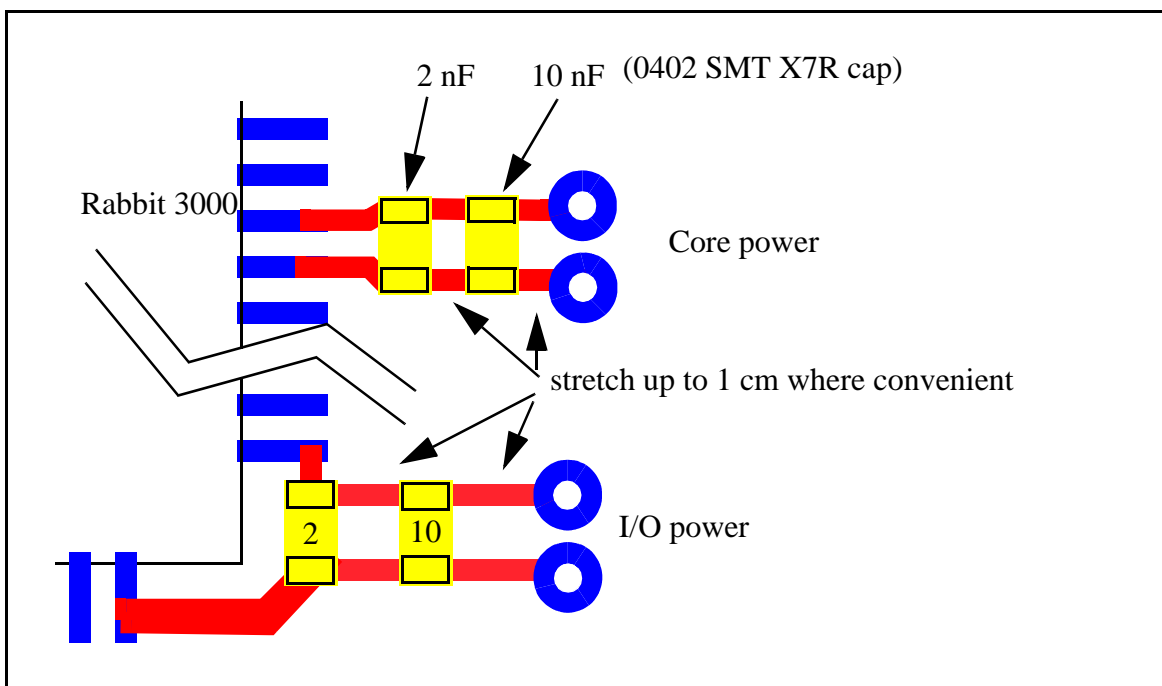

Figure 2. Processor and PC Board Decoupling

The decoupling capacitors may be placed on the “back side” of the PCB relative to the Rabbit 3000 if there is not enough room on the Rabbit 3000 side of the PCB. See Figure 3.

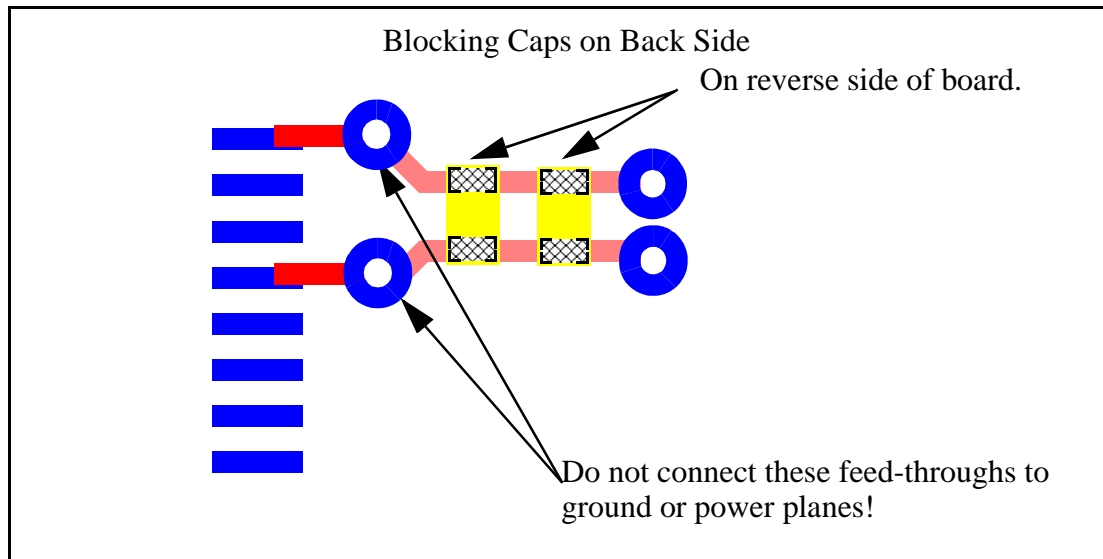

Figure 3. Placing Decoupling Capacitors on the “Back” Side of the PCB

The photo in Figure 4 shows the pairs of capacitors at each pair of power and ground pins, except for the pairs attached to pins 51 and 48 and to pins 112 and 115. These capacitors are located on the reverse side of the board. If the unfiltered signal from the power pins is passed through the board, it is very important that it not connect to the ground or power plane before it passes through the 2-capacitor filter. Typically PC board layout programs are prone to make this connection automatically unless the signal name is not identified as power or ground.

NOTE: All of the layout recommendations described in this technical note have not been followed for the board shown in this photo, but the board still functions quite well.



Figure 4. Decoupling Capacitors Around Rabbit 3000 Power and Ground Pins

Decoupling Capacitors Around Memory Chips

Memory chips can be decoupled as shown in Figure 5. If the memory chip is fast or has adjacent ground and power pins, then both ground and power can be isolated from the power planes in the same manner as the processor. For TSOP packages it is difficult to build an isolated power and ground supply because that would require running a low-inductance (wide) ground trace under the package.

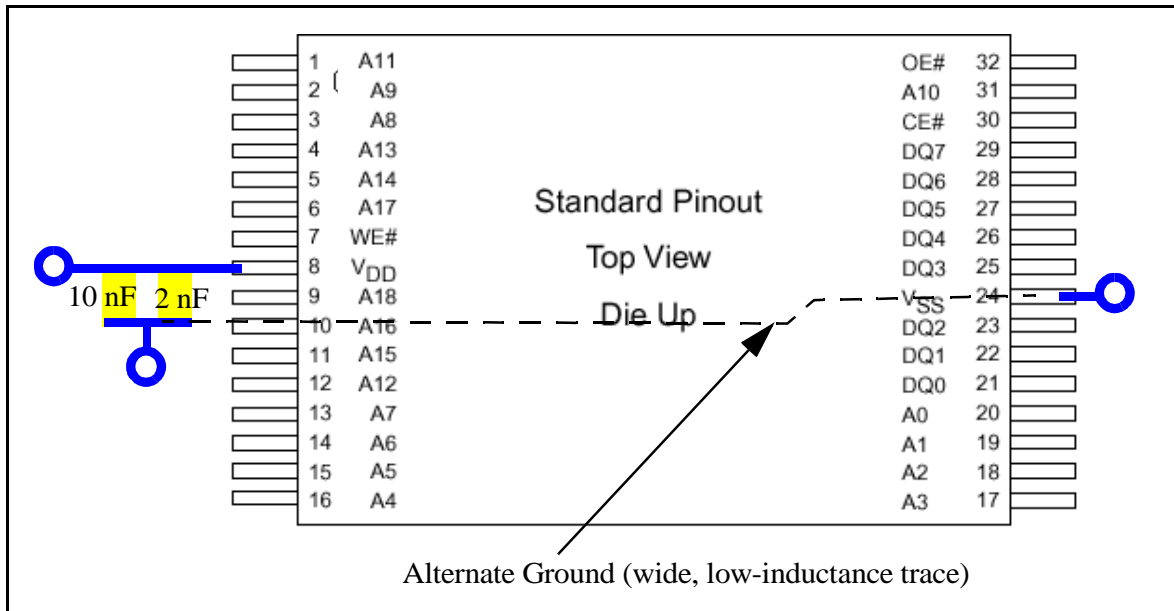

Figure 5. Decoupling TSOP Memory Chip

Decoupling Capacitors Between PCB Power and Ground Planes

Although we think it is *possible* to design a 2-layer printed circuit board with reasonable EMI, at least at low clock frequencies, a minimum of a 4-layer printed circuit board with a separate ground and power planes is recommended. The PC board “stackup” or manufacturing instructions should provide for minimal separation between the power and ground planes so as to maximize power-ground capacitance and to minimize impedance. Usually these planes can be separated by 2 or 4 mils (0.05 or 0.10 mm). If you do not specify the stackup, you will likely end up with a 16 mil (0.4 mm) separation, which will increase high-frequency noise by a large amount, perhaps by as much as 12 dB. A 2 mil (0.05 mm) separation can be achieved by using a prepreg material between the power and the ground planes. If a separate fiberglass core is used with plating on both sides, then the minimum separation is usually 4 mils (0.10 mm).

If you are using a RabbitCore module based on the Rabbit 3000, you may consider using a 2-layer motherboard because RabbitCore modules have such low emissions.

The power and ground planes should be connected by decoupling capacitors that are in addition to capacitors used to decouple the processor and the memory chips. Since decoupling capacitors are relatively ineffective at frequencies above 100 MHz, use a number of small capacitors in parallel to achieve high-frequency decoupling—about ten 2 nF capacitors, five 10 nF capacitors, and four 100 nF capacitors. The 2 nF and 10 nF capacitors should have double vias at each connection to keep the inductance low. The more cables and other devices there are connected to the board, the more important the decoupling is between the power and the ground planes.

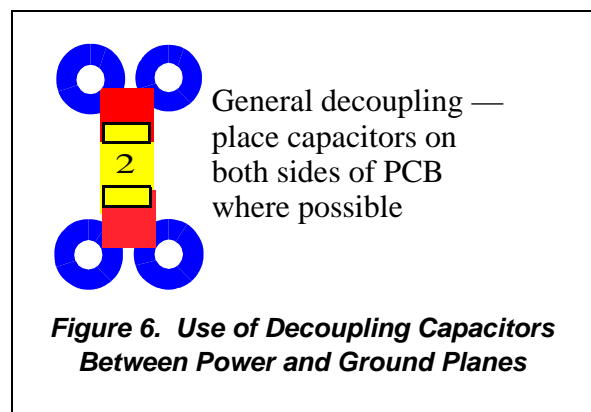

Since routing traces in the ground plane creates, this practice should be avoided, particularly if the slot is crossed by traces carrying heavy current at high frequency. The reason is that the return current in the ground plane that normally flows under the trace at high frequencies will be diverted around the slot, creating a current loop that may radiate significantly if the loop area is large.

Cables Attached to the PCB

Cables connected to the PC board can serve as antennas if they have high-frequency common-mode noise* coupled to them. The noise can be coupled to the shield of a cable, to all wires of twisted pairs or cable bundles, or to a single wire. The noise can get on the cable by capacitive coupling from the ground and power planes, via the driver power supply, or by passing through the driver circuitry. In Figure 7 the driver has been provided with its own filtered power supply, and the ground and power planes have been cut away to prevent capacitive coupling to the traces exiting the driver, the connector, or the cable. It may also be necessary to filter the signal entering the driver if the driver has the capacity of passing high-frequency noise. Drivers that spend most of the time either on or off have saturated transistors and may only pass noise from the power supplies and not from the signal input. Surface-mount ferrite beads can be used to filter the signal and also as an alternative to the resistors shown in the power supply filter for the driver. Even a few picofarads of coupling capacitance to a noisy ground can be important at frequencies of 200 MHz or higher if the cable length and configuration makes it a good antenna. Avoid dangling cables, which will behave like antennas, when running EMI tests. Instead, route the cables close to a metal chassis, as you would in an actual system installation. Remember you are not obliged to set up the EMI testing in such a manner as to assure failure. Your obligation is to set up the test in a manner that is representative of real-world installation practices, including your own recommendations to your customers as to how to install your equipment. Remember, too, that practices that reduce radiation also reduce susceptibility to strong electric fields that might disturb the operation of the equipment.

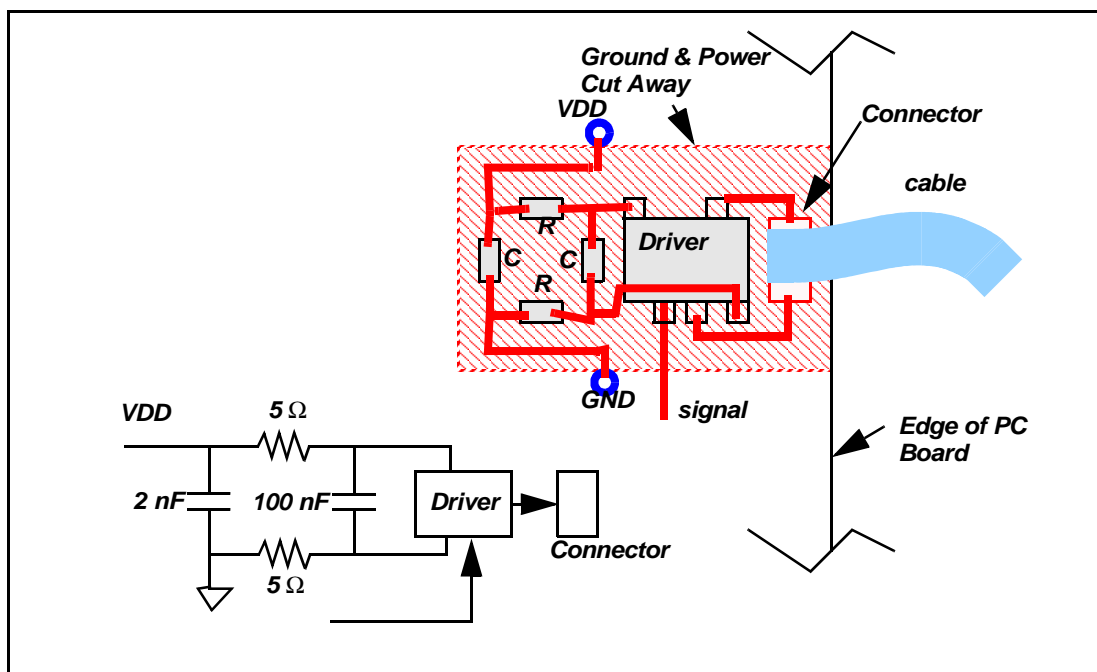

Figure 7. Decoupling RS-485 Cable Driver Chip

* Common-mode noise refers to noise coupled commonly into both wires of a twisted pair or into the shield of a shielded wire.

Clock and Oscillator Considerations

Pin 1 of the Rabbit 3000 can be programmed to output the internal clock or the internal clock divided by 2. The Z-World BIOS automatically disables this pin. To minimize EMI, avoid using this pin as a clock output. Most Rabbit designs don't need to use the clock output pin explicitly. However, in cases that require a clock, use clock/2 if possible. Also, a series resistor can (and should) be placed in the clock line to slow down the rise and fall times, which will reduce radiated emissions at higher harmonics of the frequency. Place the resistor, which might be around 1 k Ω , as close to pin 1 as possible. The capacitive load of whatever the clock line is connected to, along with the resistor, creates an RC time constant that slows the edge. If the capacitive load is larger, a smaller resistor is needed and vice versa.

Keep the clock line as short as possible, and run it over a ground plane or—better yet—between two ground planes. Position the clock line well away from other traces, especially traces running parallel to it for any distance.

The external oscillator circuit that uses the built-in oscillator buffer of the Rabbit will not generally be a significant source of radiation since the edges are slow and the oscillator normally runs at ½ the clock frequency if the clock doubler is used. If a separate oscillator unit with fast rise times is used, then it may be useful to take some precautions in routing and controlling edge rates.

Practical Examples

The graph in Figure 8 below shows the levels of ground-to-power noise measured by connecting the spectrum analyzer between the ground and the power planes on a PCB with a Rabbit 3000 operating at 29.49 MHz. The spectrum shown corresponds to the signal passing through a 120 kHz filter, the same bandwidth used for government EMI tests. The measurements here are direct-contact measurements of ground-to-power noise on the printed circuit board, and should not be confused with the measurements made by connecting the spectrum analyzer to an antenna—although there will be a relationship that depends on the geometry and the circuitry of the PC board.

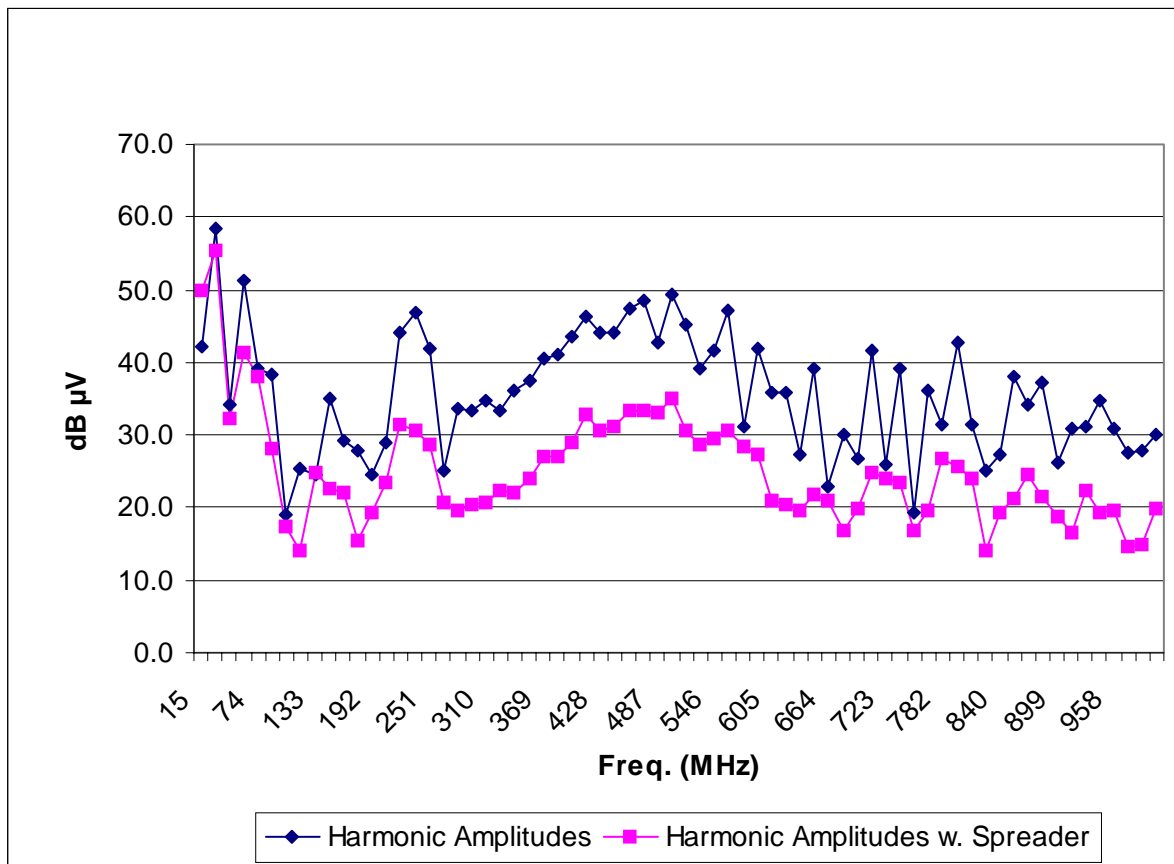

**Figure 8. Ground-to-Power Noise Spectrum 120 kHz Bandwidth
Rabbit PC Board Operating at 29.5 MHz**

If you follow the guidelines given in this technical note for decoupling and spacing for the ground and power planes, your board will probably be within 10 dB of the values shown in the graph. The spectrum shown in the graph with the clock spectrum spreader off appears to be a noisy signal, when observed on an oscilloscope, with excursions of approximately 20 mV. The rms amplitude is also on the order of 2 mV.

We will give some examples of the expected radiation from attached cables in various configurations given this degree of power-ground noise.

Cable is a Perfect Antenna, Shield Coupled to Ground Plane

This example illustrates a worst-case type of situation. Notice that the graph in Figure 8 shows a peak of around 35 dB at about 147 MHz with the spectrum spreader turned off. The amplitude at the same frequency drops to about 23 dB when the spectrum spreader is turned on.

Assume that a cable shield is attached directly to the ground plane, and calculate the radiation for 147 MHz with the spectrum spreader off and on. Assume that the cable is a perfect whip antenna $\frac{1}{4}$ wavelength long sticking straight up above a ground plane that the board is embedded in. The power-ground noise is $56 \mu\text{V}$ (35 dB μV) with the spectrum spreader off, and $14 \mu\text{V}$ (23 dB μV) with the spectrum spreader on. Cut these values in half based on the assumption that the excursions of the ground plane relative to earth ground are $\frac{1}{2}$ as great as the power-ground excursions. A whip antenna has a feedpoint impedance of 36Ω . The current will be $28/36 = 0.77 \mu\text{A}$ with the spectrum spreader off, or $7/36 = 0.19 \mu\text{A}$ with the spectrum spreader on. The $\frac{1}{4}$ wavelength antenna will be 0.51 m long. Using the equation for common-mode radiation given previously, the radiation level at 3 m will be $30 \mu\text{V/m}$ or 29.5 dB $\mu\text{V/m}$, which is 13.5 dB below the FCC Class B limit of 43 dB $\mu\text{V/m}$ @ 3 m at this frequency. With the clock spectrum spreader on, the radiation will be $7.5 \mu\text{V/m}$ or 25.5 dB $\mu\text{V/m}$, 21 dB below the FCC Class B limit.

These numbers could easily be 20 dB lower if the antenna is not “perfect,” for example, if the antenna is not exactly $\frac{1}{4}$ wavelength or if it is not sticking straight up into space above a perfect ground plane. Thus, the EMI radiation at 147 MHz will likely be $25 + 20 = 45 \text{ dB } \mu\text{V}$ *below* the FCC Class B limit. Note that European standards and tests are similar to the FCC standards and tests.

If the shield is coupled through a 5 pF capacitor instead of being connected directly to the ground plane, the radiation emitted will be reduced even further. The capacitor has an impedance of 216Ω at 147 MHz ($Z = 1/(2*\pi*f*C)$). The 5 pF coupling capacitor will reduce the current by a factor of 6 ($36 \Omega/216 \Omega$), or 16 dB compared to a direct connection.

Having multiple cables will probably not increase the radiation a great deal provided that they are all well decoupled from noise sources, since the various cables will not be tuned to the same frequencies or radiate in the same direction.

If it is necessary to connect a cable shield to ground for safety or other reasons, it may be possible to use a ferrite bead that has a high resistance at high frequencies but a low DC resistance. A common-mode choke is a device that can be used to remove common-mode voltages from twisted-pair wires such as RS-485 cabling. If these chokes are used, keep in mind that capacitive coupling will still be present.

This example reflects results that are already 40 dB or a factor of 100 below the FCC Class B limits.

Figure 9 shows the radiated noise up to approximately 500 MHz for the example RCM3100 board with the spectrum spreader at the normal setting. The radiated noise was not detectable above this frequency because it was too far below the background noise level. From the graph it appears that additional decoupling in the range of 30–100 MHz (using 2 nF and 10 nF capacitors) would be effective in further reducing ground-power noise and thus radiated noise. The noise is probably being radiated from the power cable, which is acting as an antenna. It should be realized that the radiated noise shown below would be quite difficult to detect using the standard FCC 120 kHz filter since it is below the noise level (typically 25 dB $\mu\text{V}/\text{m}$ @ 3 m) encountered with an open-field test site. A 200 Hz wide filter was used to make these measurements.

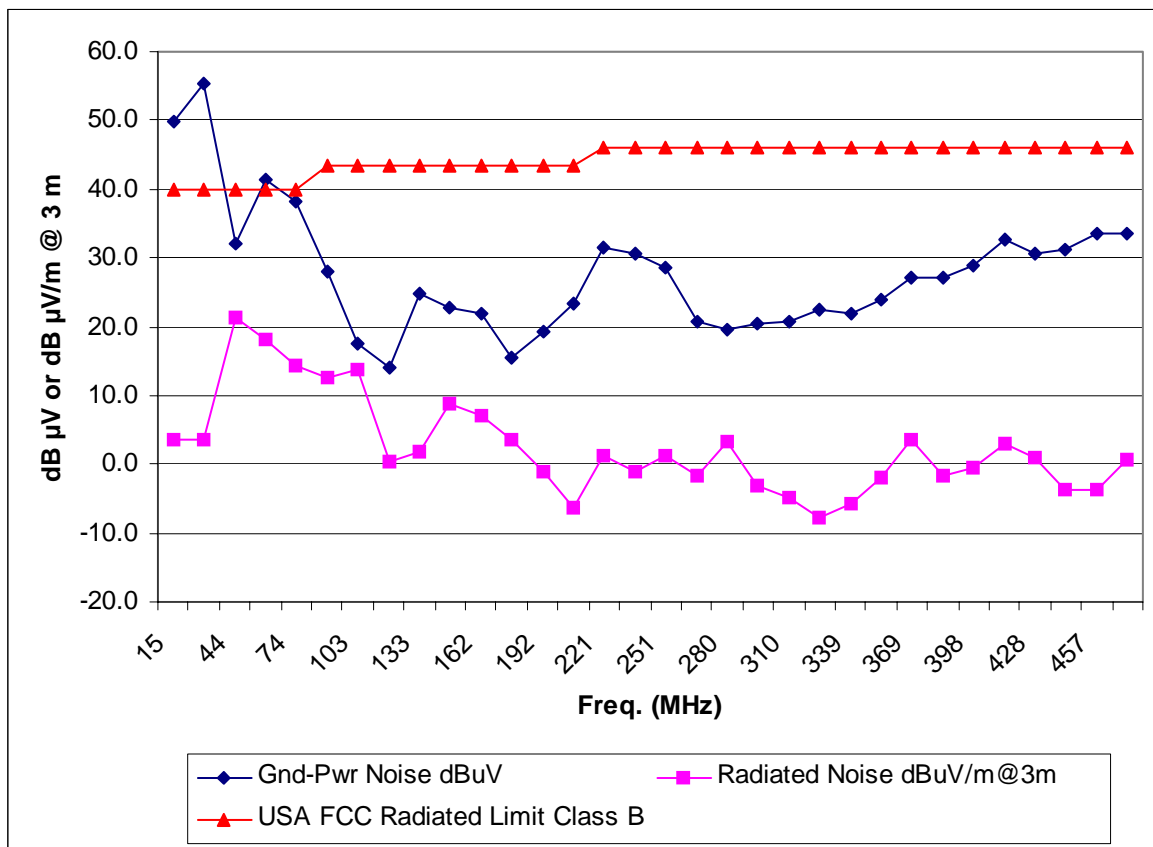

Figure 9. RCM3100 Radiated Noise With “Normal” Spectrum Spreader Enabled

NOTE: Do not confuse the line labeled **Gnd-Pwr Noise dBuV** with the radiated levels. These measurements resulted from a direct connection of the spectrum analyzer to the board power and ground.

Power-Supply Cables

If high-frequency common-mode noise is present on the power-supply cables, then the entire board can serve as an antenna relative to the power-supply ground, and that noise will be added to the noise on other attached cables. If power is supplied directly to the PC board via a long pair of wires, then one wire is attached to VDD and the other is attached to ground or VSS. In this case, the incoming pair of wires should be isolated from capacitive coupling to the ground or power planes, and should be connected directly to a large and small capacitor in parallel, and then to the planes. The same precautions should be taken if unregulated voltage or AC is brought to the board and passed into a local regulator. Common-mode currents in the power cable can also be reduced by wrapping the cable around a ferrite filter or by installing a common-mode choke.

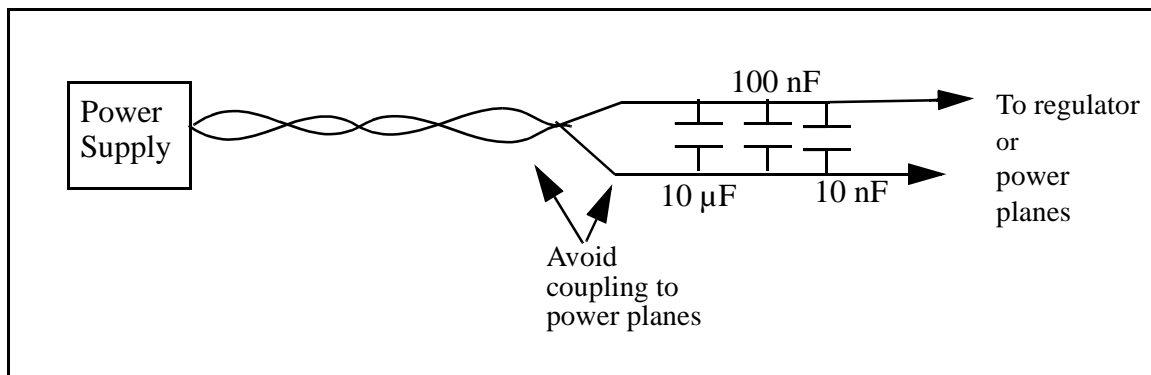

Figure 10. Power Supply Connections

Motherboard/Daughter Board

In a motherboard/daughter board or a digital backplane it is usually necessary to make a low-inductance common ground. Anything else will result in ground bounce if fast signals travel from one board to another. The ground bounce is created when the fast return current attempts to pass through the connecting inductance between the boards. However, VDD can be filtered before it exits a noisy board and connects to the VDD on a mother or daughter board that does not have high-frequency noise sources (processors). The worst situation is distributing a common clock to a number of different connected boards. To minimize such problems, the clock should have the slowest rise time possible (for example, use a series 1 kΩ resistor near the clock source) so as to reduce the higher frequencies, or better, distribute the clock using a differential driver and a transmission line consisting of two conductors. This will avoid return currents through ground.

Summary

If the suggested design guidelines are followed, and common-mode coupling to attached cables is minimized, then radiated emissions can be expected to be 40 dB or more below government limits.

The design recommendations are summarized below.

- Enable the spectrum spreader. Use the spectrum spreader unless there is a compelling reason not to. (15 dB)
- Filter the Rabbit package power-supply pins with a pair of decoupling capacitors for each pair of pins arranged as suggested. (15 dB)
- Use a 4-layer or a 6-layer PC board with the VCC and the ground planes on the inner layers, separated by no more than 4 mils spacing; 2 mils is even better. (10 dB)
- Add 2 nF and 10 nF decoupling capacitors with low-inductance connections to the power planes liberally throughout the PC board. Add a few 100 nF decoupling caps. (10 dB)
- Decouple the power-supply input lines and filter incoming power as shown in Figure 10.
- Decouple memory chips as shown in Figure 5.
- Don't connect cable shields directly to the ground plane (use a series ferrite if additional decoupling is needed—the use of ferrites is not usually necessary).
- Avoid slots in the ground or power planes.
- Cut away ground and power planes near connectors to avoid common-mode coupling to attached cables.
- Don't run clocks on the board, but if you absolutely must, place them near the ground plane and minimize rise times by using a series resistor.
- Consider filtering the cable drivers' power supply.
- If your PC board connects to another board via a connector (motherboard/daughter board), then filter VCC before it leaves the board.
- Use address line A1 instead of A0 to access non-memory devices located on the high-speed memory bus, particularly if the line is long.

Of course, radiated emissions from your board might not have to be 40 dB below the FCC Class B limit. Many users will be satisfied when the radiated emissions are 5 dB under the limit. However, most of these suggestions involve no extra expense, so there is no reason not to implement them.

Z-World, Inc.

2900 Spafford Street
Davis, California 95616-6800
USA

Telephone: (530) 757-3737
Fax: (530) 757-3792

www.zworld.com

Rabbit Semiconductor

2932 Spafford Street
Davis, California 95616-6800
USA

Telephone: (530) 757-8400
Fax: (530) 757-8402

www.rabbitsemiconductor.com